



Robot Penalty	Level	Team	Building
Shoot-Out	Junior / Senior	1-2 person	Pre-Made

Overview

Penalty kicks are one method of determining the winner in football. In this Robot Penalty Kick Competition, each team will be allowed 5 attempts. The team with the highest score after all attempts is declared the winner.

Robot Specifications

1. Each robot may use no more than **4 motors**.
2. The robot must not exceed the following dimensions:

Width: 200 mm, Length: 300 mm, Height: 240 mm,

and must weigh **no more than 1,500 grams**.

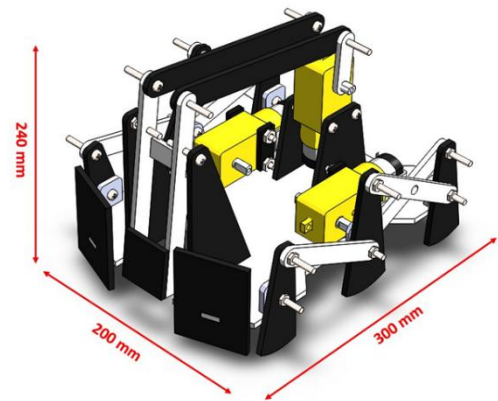

3. The robot must move in a **walking-like motion**.
4. The robot must be controlled via a **wired remote control only**. The control cable must be **elevated at least 240 mm above the ground** at all times. The cable **must not touch the ground** during the competition.
5. The **maximum battery voltage** allowed is **8.4 volts**.
6. **Rechargeable batteries** are permitted.
7. **Li-Po (Lithium Polymer) batteries** are **not allowed**.
8. The **front of the robot** must be equipped with slanted walls on both sides, sloping toward the rear, to prevent the walking legs from touching the ball.
9. The **kicking mechanism** must be designed to **swing**, not rotate. The direction of the kick must be **forward-facing**, relative to the robot.
10. **No modifications or adjustments** to the robot are allowed during the competition.



Competition Field Specifications

1. The competition field has dimensions of **1200 mm x 1200 mm**. The goal is **400 mm wide and 150 mm high**.
2. A **tennis ball** will be used as the football for this competition.

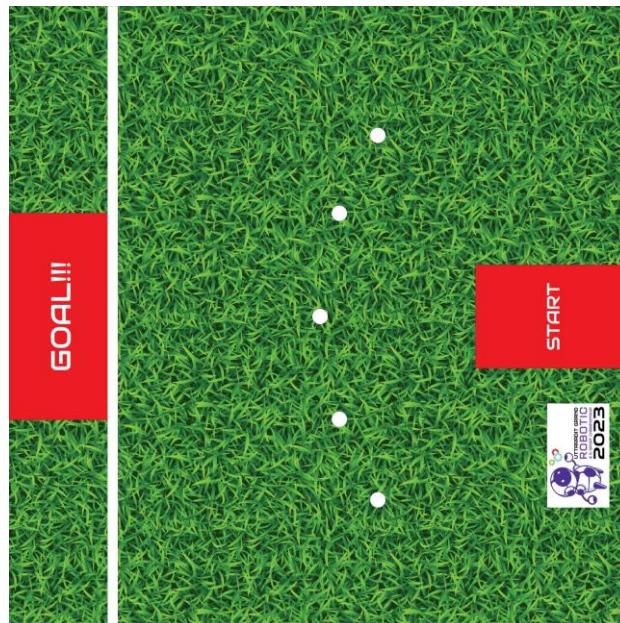

Competition Rules

1. The participant must place the robot at the starting point. Upon hearing the referee's signal, the participant will control the robot to kick the footballs one at a time, out of a total of 5 balls. The total time allowed for the competition is 3 minutes.
2. A goal is considered valid only when the ball completely crosses the goal line. The robot is allowed to kick each ball only once per attempt.
3. Each team is allowed 2 rounds of competition. The referee will take time and record the score for each round. The best result from the two rounds will be used for the ranking. The team with the shortest time and highest score will be declared the winner.